

400MCT RT1100



Tesmec 400MCT with RT1100 is a 14 metric ton-class trencher featuring a 238 Hp (175 kW) Tier 4/ Stage V engine, or a 218 Hp (160 kW) Tier 3 engine, designed for telecom and energy cables projects in urban and extra-urban areas

STANDARD FEATURES

Productivity Exploit the productivity of 400 MCT tractor and RT1100 tangential wheel attachment, with an hydraulic offset of 70 cm (2' 4" from machine centerline either direction, +/- 12° hydraulic tilt (rotation about horizontal axis) and +/- 13° hydraulic pivot (rotation about vertical axis). These are offered as standard with crumbshoe, TrenchTronic and Re.M.

Modularity Enhance 400MCT potential thanks to its modularity. This model is available also with R670 axial wheel, CS1200 chainsaw and VP1100 vibratory plow, making it the ideal solution for multiple applications.

Remote controlled Experience the radio control system, which enables the operator to control the machine remotely, increasing the safety in site, the visibility on the trenching area and on the trenching tool.

OPTIONAL FEATURES

- Kit Extra Offset max 34 cm (1' 1")
- Rubber track pads
- Reel carrier, rollers and laying box for mechanical laying
- Smart Tracker

STATE OF THE ART TECHNOLOGY

TrenchTronic Electronic control with operator selectable digging pressure, fully automatic operation, and remote diagnostic system

Re.M The remote monitoring system with machine data remote monitoring, fleet location management, troubleshooting information and operating conditions

Smart tracker Automatically collects as-built data while the machine is trenching, avoiding survey stakeout and achieve the complete digitalization of the jobsite.

TRENCHING DIMENSIONS

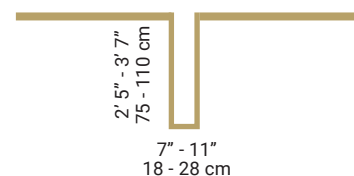

TRANSPORT DIMENSIONS

	METRIC	US
Lenght	824	27' 0"
Width	183 cm	6' 0"
Height	261 cm	8' 7"
Weight	13.500 - 15.500 Kg	29.700 - 34.100
Ground pressure	0.70 - 0.80 kg/cm ²	9.9 - 11.3 psi

ENGINE

	METRIC	US
Model and Max HP (kW)		
Tier 4/Stage V VOLVO TAD583VE	238 HP (175 kW)	
Tier 3 VOLVO TAD552VE	218 HP (160 kW)	
Max no load rpm	1.700 RPM	
Fuel tank capacity	190 L	50.2 gal
Fuel consumption (at full load)		
Tier 4/Stage V	41.8 L/hr	11.04 gal/hr
Tier 3	44 L/hr	11.62 gal/hr
AD Blue/DEF consumption		
Tier 4 / Stage V	2.59 L/hr	0.68 gal/hr
Cooling rating	54°C ambient air	130°F ambient air
Air cleaner	Power Core	

TRACKS

	METRIC	US
Track chain type	FL4	
Track lenght	241 cm	7' 11"
Track pad width	40 cm	1' 4"
Track pad type	Triple grouser (single available as option)	
Self-leveling (tilting) undercarriage	20 cm	0' 8"

CRAWLER DRIVE

	METRIC	US
Drive	Hydraulic open circuit, planetary transmission	
	Full counter rotation	
Infinitely variable speed	Forward and reverse	
Working speed	0 - 1.16 km/h	0 - 0.72 mph
Transfer speed	0 - 1.93 km/h	0 - 1.20 mph
Parking and service brake	Spring applied, hydraulic release, wet disc brake	

DIGGING DRIVE

	METRIC	US
Drive	Hydrostatic, one variable displacement pump and one motor	
Digging speed ranges	0 - 270 m/min	0 - 885 fpm
Cutters	Rotary carbide tipped	
Cutters shank diameter	2.5 cm	1"
Cutters gage	6.5 cm	2"

TRUCK LOADING CONVEYOR

	METRIC	US
Not available in this configuration		

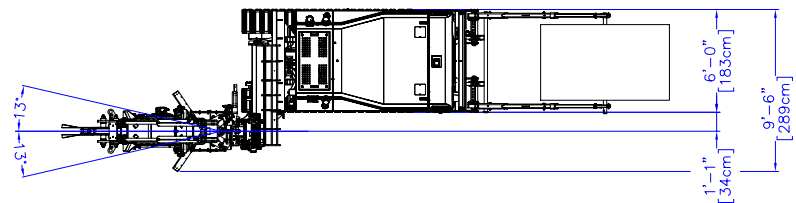
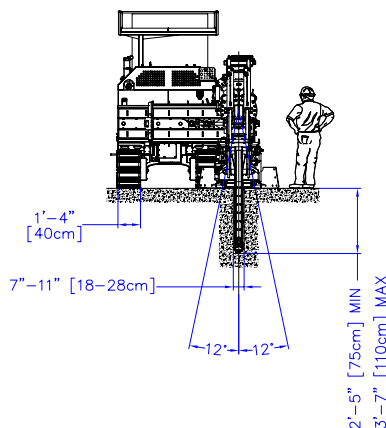
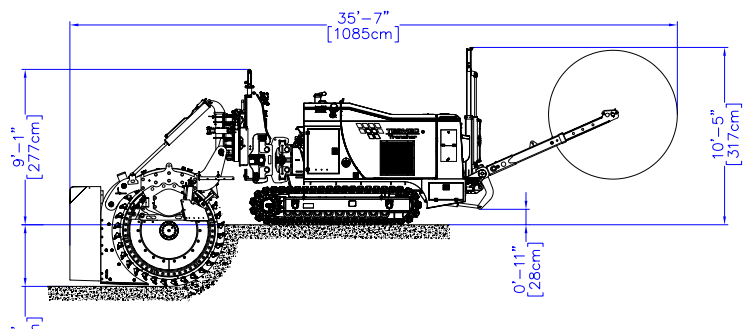
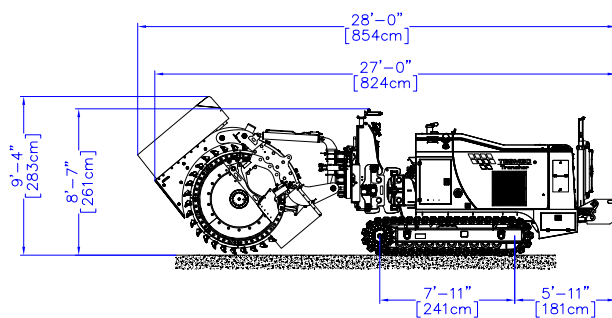

Pictures & drawings can be different according to technical specifications - Updating programme variations without notice are possible