

MTR430 CT1300



Tesmec MTR430 with CT1300 is a 33 metric ton-class trencher featuring a 428 HP (315 kW) engine designed to optimise the mechanized laying of networks in rural and urban environments

STANDARD FEATURES

Productivity Exploit the productivity of MTR430 with CT1300 chainsaw attachment, featuring an hydraulic offset of 184 cm (6'1") from center to right side, +/- 15° hydraulic tilt (rotation about horizontal axis) and +/- 5° hydraulic pivot (rotation about vertical axis). These are offered as standard with cross conveyor, crumbshoe, security kit and TrenchTronic.

Modularity Enhance MTR430 potential thanks to its modularity. This model is available also with R1200 wheel, R1400 wheel and R620 wheel, making it the ideal solution for multiple applications.

Remote control Experience the radio control system, which enables the operator to control the machine remotely, increasing the safety in site, the visibility on the trenching area and on the trenching tool.

OPTIONAL FEATURES

- Closed cabin, pressurized with heating and air conditioning
- Wired control
- Cameras
- Lateral conveyor and truck conveyor
- Working light kit
- Accessories for mechanized laying
- Re.M
- Smart Tracker

STATE OF THE ART TECHNOLOGY

TrenchTronic The remote control with machine data remote monitoring, fleet location management, troubleshooting information and operating conditions

Re.M The remote monitoring system with machine data remote monitoring, fleet location management, troubleshooting information and operating conditions

Smart tracker Automatically collects as-built data while the machine is trenching, avoiding survey stakeout and achieve the complete digitalization of the jobsite

TRENCHING DIMENSIONS

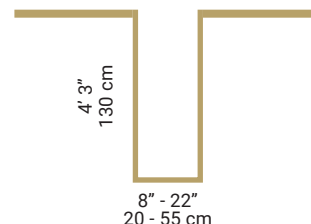

TRANSPORT DIMENSIONS

	METRIC	US
Length	1488 cm	48' 10"
Width	250 cm	8' 2"
Height	341 cm	11' 2"
Weight	32.680 - 33.140 Kg	72.000 - 73.000 lbs
Ground pressure	0.74 - 0.76 kg/cm ²	10.5 - 10.8 psi

ENGINE

	METRIC	US
Model and Max HP (kW)		
Tier 4/Stage V VOLVO TAD1382VE	428 HP (315 kW)	
Max no load rpm	1.700 RPM	
Fuel tank capacity	840 L	222 gal
Fuel consumption	90 L/hr	24 gal/hr
AD Blue/DEF consumption	4.5 L/hr	1.19 gal/hr
Cooling rating	50°C ambient air	122°F ambient air
Air cleaner	Dry type, 2 stages with dual pre-cleaner	

TRACKS

	METRIC	US
Track chain type	B4	
Track length	442 cm	14' 6"
Space idler / sprocket	365 cm	12'
Track pad type	Triple grouser	
Track pad width	60 cm	2' 0"
Tilt Undercarriage	+/- 2.5°	

CRAWLER DRIVE

	METRIC	US
Drive	Dual path, hydrostatic, planetary transmissions	
	Full counter rotation with double lever steering and double lever direction	
Infinitely variable speed	Forward and reverse	
Transfer mode driving	0 - 2.2 km/h	0 - 1.37 mph
Work mode driving	0 - 1.28 km/h	0 - 0.80 mph
Parking and service brake	Hydraulic due to lack of pressure	

DIGGING DRIVE

	METRIC	US
Drive	Hydrostatic, one pumps and one motor	
Digging speed ranges	0 - 180 m/min	0 - 590 fpm
Digging chain	Tesmec single strand with 11.4 cm (4.5") pitch chain, "K" or "M" style	
Digging chain adjustment	Positive locking	
Cutters	Rotary carbide tipped	
Cutters shank diameter	2.5 cm	1"
Cutters gage	6.4 cm	2' 1/2"

CROSS CONVEYOR

	METRIC	US
Conveyor belt speed	0 - 240 m/min	0 - 787 fpm
Conveyor travel	30 cm	12"
Conveyor extensible	90 cm	2' 11"
Conveyor belt width	50 cm	1' 8"
Conveyor discharge direction	Right or left	
Conveyor length	188 cm	6' 2"

LATERAL CONVEYOR

	METRIC	US
Conveyor position	left side	
Conveyor belt speed	0 - 180 m/min	0 - 590 fpm
Conveyor belt width	45 cm	1' 6"
Conveyor length	827 cm	27' 2"
Conveyor tilt angle	4° (transport position) - 25.6° (working position)	

SWING TRUCK

	METRIC	US
Conveyor belt speed	0 - 240 m/min	0 - 787 fpm
Conveyor belt width	45 cm	1' 6"
Conveyor length	240 cm	7' 11"
Conveyor horizontal tilt angle	-15° / +15°	
Conveyor vertical tilt angle	-14° / +15°	
Discharge height (swing conveyor)	401 cm	13' 2"

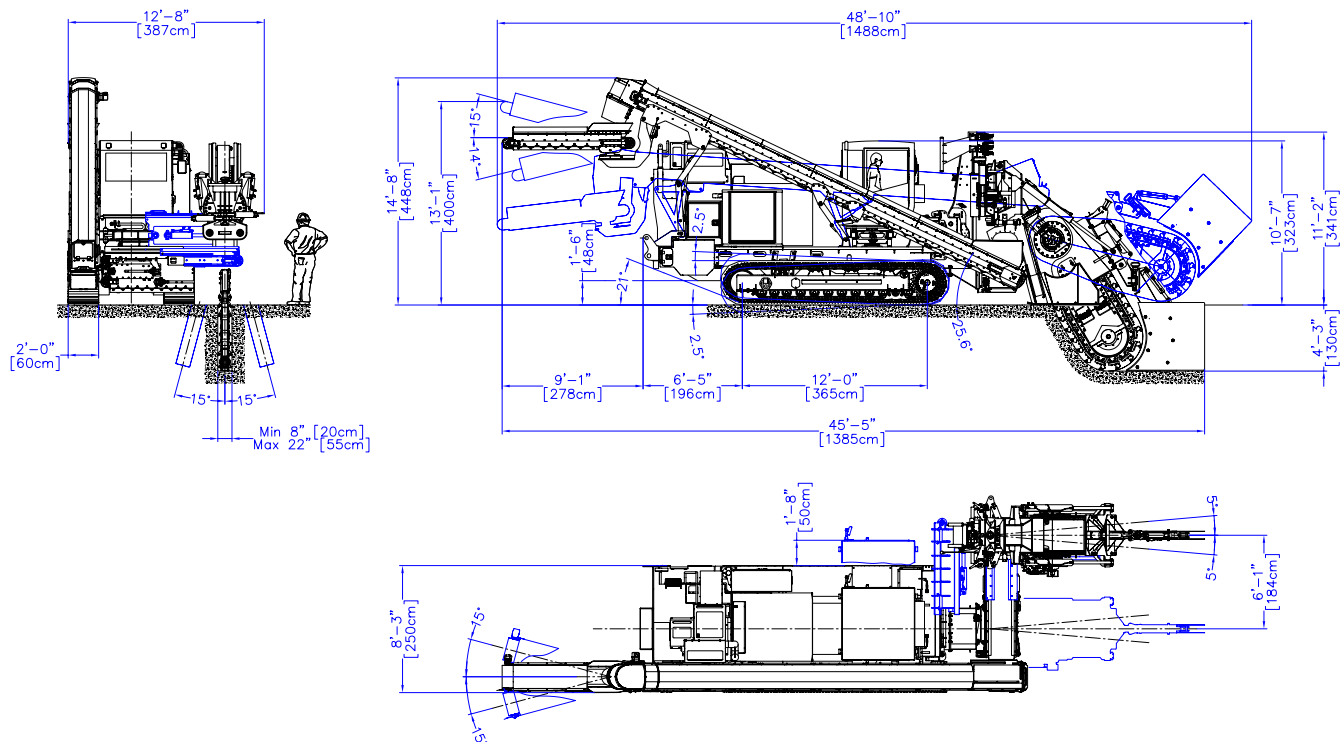

Pictures & drawings can be different according to technical specifications - Updating programme variations without notice are possible

TESMEC
draw the way forward

[in](#)
[yt](#)
[ig](#)
[fb](#)
www.tesmec.com